

DETAIL B
SCALE 5 : 1

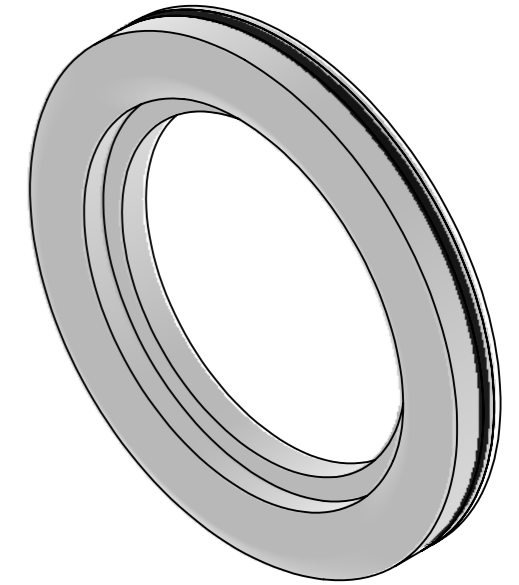

Design Table for: 0907P0004

DN 11851	D1	D2	D3	S
DN10	19,8	12	10,5	5
DN15	25,8	18	16,5	5
DN20	32,8	23	20,5	5
DN25	39,8	30	26,5	5,5
DN32	45,8	36	32,5	5,5
DN40	51,8	42	38,5	5,5
DN50	63,8	54	50,5	5,5
DN65	80,8	71	66,5	5,5
DN80	94,8	85	81,5	5,5
DN100	113,8	104	100,5	6,5
DN125	141,8	130	125	7,5
DN150	166,8	155	150	7,5

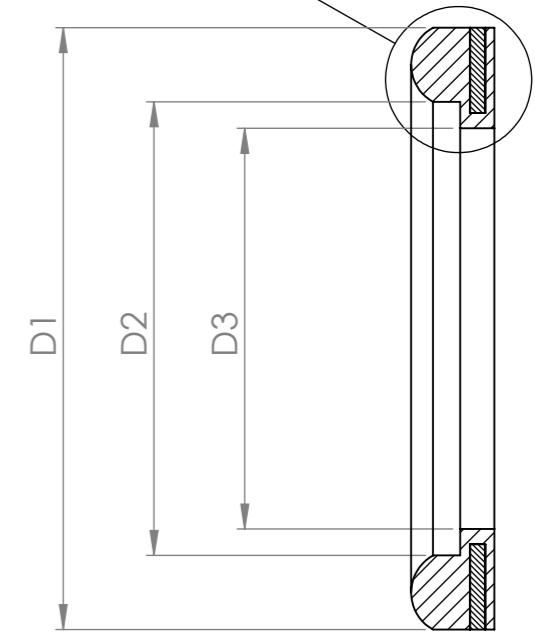
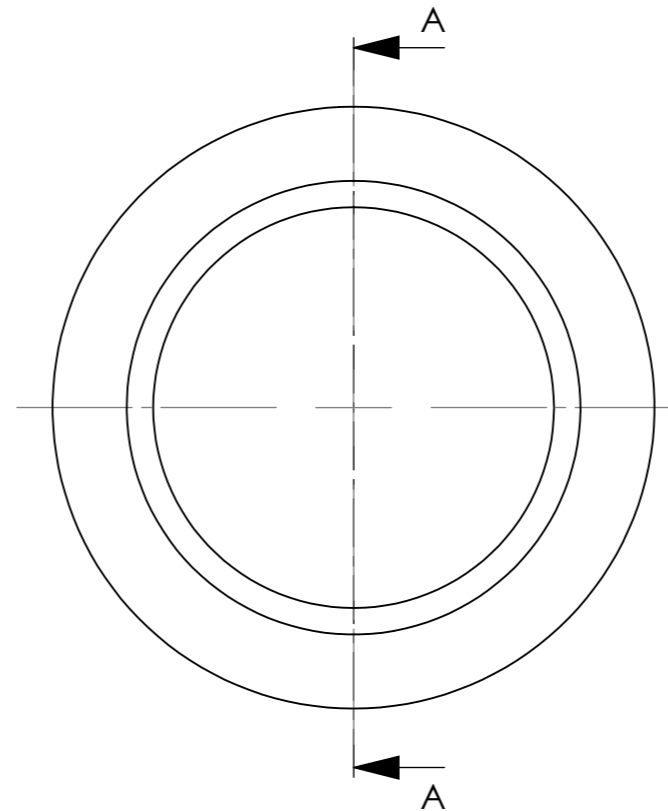

SECTION A-A

UP Ultrapharma

info@ultrapharma.com 1967 DB Heemskerk T: +31-(0)251-207050
www.ultrapharma.com The Netherlands F: +31-(0)251-207055

CONFIGURATION: DN25 DESCRIPTION: DIN 11851 PTFE + FKM ENVELOPE

The information contained in this drawing is the sole property of Ultrapharma BV. Any reproduction in part or as a whole without written permission of Ultrapharma BV is prohibited.



UNITS: mm SCALE: 2:1 SHEETSIZE: A3